

BALL VALVE – EXTENDED BUTT WELD

C2JBB64-G

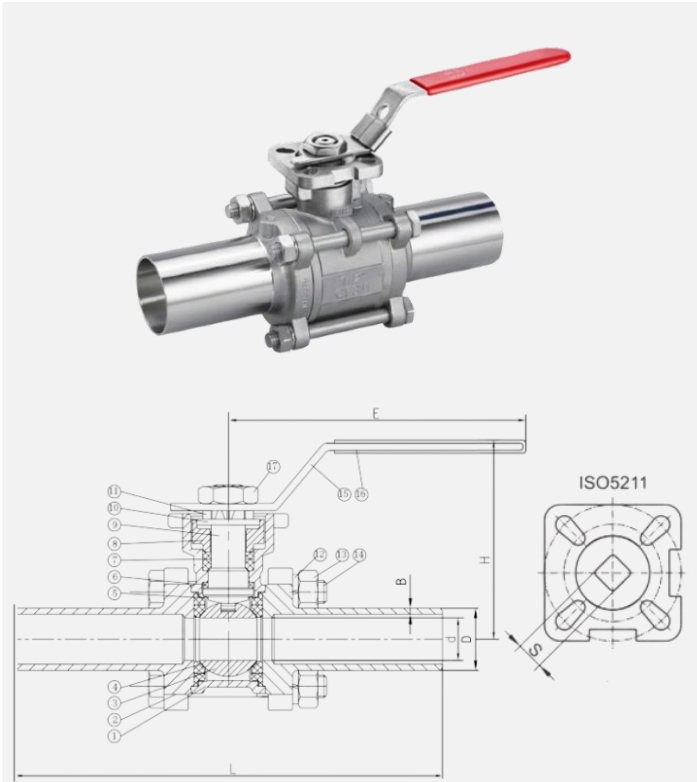

TECHNICAL REQUIREMENTS

Test & Inspect conform to EN12266
The platform size conforms to ISO5211

Part number	Part name	Material
1	BODY	316
2	CAP	316
3	BALL	316
4	SEAT	TFM1600
5	JOINT GASKET	PTFE
6	THRUST WASHER	PTFE
7	PACKING	PTFE
8	GLAND BUSH	304
9	STEM	304
10	SPACER	304
11	WASHER	304
12	WASHER	304
13	NUT	304
14	BOLT	304
15	HANDLE	201
16	HANDLE COVER	PVC
17	BOLT	304

TECHNICAL PARAMETERS

Test Pressure PN63
Applicable Temperature -50~120°C
Applicable medium: water, oil, gas

DN	INCHES	d	L	D	H	E	N-M					
DN15	15	150	1.6	21.3	55	120	F03-F01					
DN20	20	155	1.6	26.9	66	135	F03-F01					
DN25	25	186	1.8	33.7	71	160	F01-F05					
DN32	32	195	2.0	12.1	81	170	F01-F05					
DN40	38	231	2.0	18.3	87	182	F05-F07					
DN50	50	213	2.5	60.3	91	220	F05-F07					
DN65	61	290	3.0	76.1	119	280	F07-F10					
DN80	76	302	3.0	88.9	125	280	F07-F10					
DN100	100	326	3.0	114.3	159	330	F10					